

The Use of Self-identifying Targeting for Feature Based Measurement

Giuseppe Ganci
Geodetic Services, Inc.
1511 Riverview Drive
Melbourne, Florida USA
E-mail: giuseppe@geodetic.com

Robert Clement
BMW Manufacturing Corporation
1400 Hwy. 101 South
Greer, South Carolina USA
E-mail: Robert.Clement@bmwmc.com

Coordinate Measuring System Committee – July 2000, Dearborn, Michigan.

KEY WORDS: Industrial Measurement, Coordinate Measurement, Photogrammetry, Videogrammetry, Coded Targets,

ABSTRACT

A powerful, new concept is described for measuring geometric features. The concept was originally developed for measuring the planes, edges and corners of the NC blocks that are commonly used in automotive fixtures. These features in particular are very difficult to measure accurately and efficiently. The concept greatly simplifies both the measurement and analysis of these features. The concept has also proven very useful for numerous other measurement applications.

The concept uses a new type of targeted adaptor called a "Feature Target", herein abbreviated as FT. Several different FT configurations are available depending on the type of feature measured. The appropriate FTs are applied to the features that require measurement. Digital photogrammetry is then used to quickly and easily measure them.

The paper describes the application of these targets in two case studies. The first study examines their use in the measurement of an automotive fixture. The second study describes the use of the targets for an in-line measurement application in an automotive production line.

INTRODUCTION

Photogrammetry is a fast, accurate 3-dimensional measurement method based on photography. The new concept described in this paper uses what is called the single-camera or sequential mode of photogrammetry. In this mode, a single high-resolution digital camera takes multiple pictures of an object from different locations. These pictures are then automatically processed to yield the 3-dimensional coordinates of points on an object. (Ganci and Handley, 1998) The sequential mode is not real-time, so it can only measure static objects and targeted points. However, it is well suited to high accuracy measurement of large, complicated objects since practically any number of pictures can be taken and processed. In addition, the photography is usually quick, so production downtime is low and temperature effects are minimized. The use of the sequential method of photogrammetry on a typical measurement is illustrated in FIGURE 1.

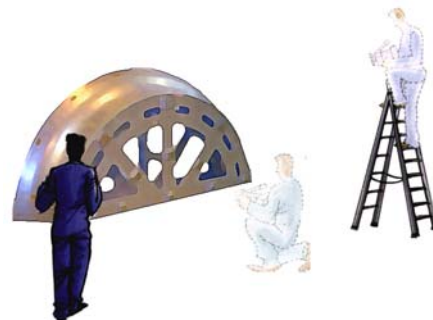

FIGURE 1 - Sequential Photogrammetry

Sequential photogrammetry has other attractive attributes including high accuracy, portability, and the ability to measure in unstable or vibrating environments. (Brown, 1998) All these attributes combined with the new concept described in this paper make sequential photogrammetry a compelling choice for numerous applications in the automotive industry.

Traditionally, three-dimensional inspection within the automotive environment takes place in a Coordinate Measurement Machine (CMM) room. The CMM room will typically have several stationary gantry-type CMMs dedicated to a certain class of dimensional inspection. This class of inspection is most notably characterized by the need to bring the part to be measured to the CMM. Such a constraint instantly disqualifies traditional CMMs from inspecting the tooling fixtures that are located on the assembly line. These fixtures are in fact the most important measured items in the factory, as they control the dimensions and fit-up of the sub-assemblies throughout the manufacturing process. In-line production measurements are also impossible using CMM systems.

Clearly, a portable measuring system that can measure items in place is desirable for many applications. Although numerous portable, in place measurement systems exist, they typically rely on touching the desired features with some type of probe or measuring adapter that is usually held in place by an operator. For many applications, access to the object is limited, making setup of the instrument difficult. Furthermore, touching the desired features with the measuring device can be difficult, tedious and prone to error.

For many automotive inspection tasks it is necessary to quickly collect and process feature data. One limiting factor until now in the use of photogrammetry for feature measurement is the need for point-of-interest targeting. For example, if a plane needs to be measured, then at least three points (>three for redundancy) need to be applied to the surface that defines that plane. Similar requirements apply to other geometric features such as circles and lines. In some instances, point-of-interest targeting cannot be used to define the feature. An edge is one example of a feature that cannot be directly targeted. Typically, a special target adapter is needed to define the edge, or the edge is determined indirectly via the intersection of two planes. This is illustrated in FIGURE 2. The example of an edge can be extended to a corner via the addition of another plane and a line-line intersection to produce the corner. Traditionally, target adapters have been an excellent way to bypass some of the problems associated with measuring difficult features such as edges and corners. The time penalty for these adapters comes at the processing stage when they need to be identified, and their measurement reduced, to yield the desired feature.

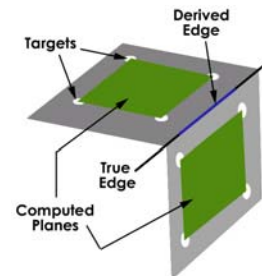

FIGURE 2 – Plane – plane intersection to derive an edge

An alternative to stick-on targeting when using photogrammetry is the use of hand-held probes to touch points of interest. (Ganci and Brown, 2000) Some typical probes are shown in FIGURE 3. These touch-probes have a standard tip, similar to the type used on conventional CMMs. In addition, each probe has five permanent targets. Two or more cameras simultaneously view these targets and calculate their XYZ position. From the XYZ position of the five targets, the probe-tip can be calculated. Probes have been successfully used in automotive applications for many years. However, in some applications setting up the cameras so they can measure the object is difficult. Furthermore, many features are hard to accurately probe especially in the tight spaces and difficult conditions encountered on many measurements.



FIGURE 3 – Assorted hand-held probes

In so far, two approaches have been discussed, point-of-interest targeting and touching by a probe. The targeting approach uses sequential photogrammetry that can often acquire the data very rapidly since photography is very quick. However, sometimes the need to target the desired features is difficult and time consuming. If, instead, a probing tool is used, there is typically setup time for the instrument, followed by the laborious probing and analysis of each feature. To circumvent both disadvantages, the focus of recent developments has been to reduce set-up time and to also remove the requirement for probing features. Substantial savings have been obtained via the use of targeting adapters known as Feature Targets (FTs).

This paper describes the principles involved and some of the characteristics of FTs. The performance of the new targeting will also be examined through reference to two case studies.

CONCEPT

The principle of FTs is now explained. They work much like an ordinary target adapter but are identified via the use of a "coded target". A coded target is made up of a unique pattern of squares and a central dot. The patterns are automatically detected, identified and measured through straightforward image processing techniques. (Fraser 1997a;b) By adding such a target to an adapter, it is possible to identify that adapter in a measurement. There are obvious advantages to automating the use and reduction of these adapters. Once a FT is identified, a calibration file associated with it is used to determine the type and the function of that particular target adapter.

The simplest FT is one for measuring a plane. This FT consists of a flat piece of aluminum with an identifying coded target applied to one side. The other side has magnets embedded in it to hold the FT in place. Such a target is shown in FIGURE 4. The relationship between the targets on the face, and the plane represented by the base of the adapter must be determined by a one-time calibration as explained below.

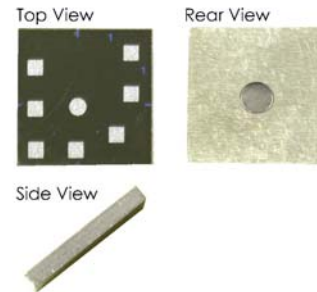

FIGURE 4 – Plane target

The FT is placed on a flat surface such as granite. Normal retro-reflective targets are placed in the area surrounding the FT target. These targets will be used to define a "local" plane. A photogrammetric measurement is then made to determine the location of the face targets relative to the local plane. Refer to FIGURE 5. With the relationship between the targets and the local plane known, the coded target and its adapter now become a feature target capable of directly measuring any plane to which it is attached. The relationship between the face targets and the plane is shown graphically in FIGURE 6.

If a right-angle bracket appropriately calibrated is used instead of a flat plate, the resulting FT can measure a plane at right angles to the face targets. The face targets on the adapter can be in any relative orientation to the plane that needs to be defined. For example, it might be desirable to have the FT at a 45° angle to the plane. In fact, the targets can be in any relative orientation providing that they can be calibrated. Moreover, multiple FTs can be placed on a block, and the feature planes they measure intersected to form a line as shown earlier in FIGURE 2.

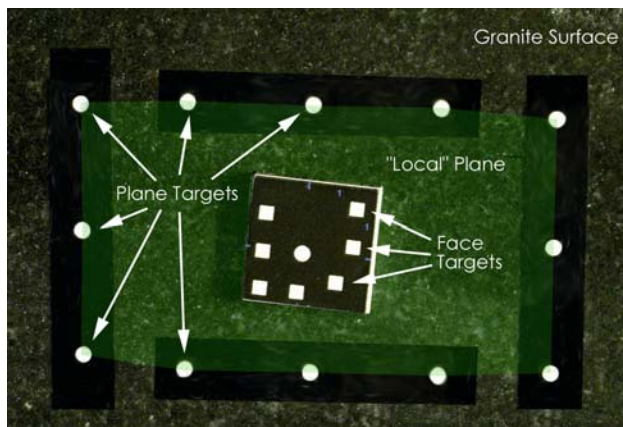

FIGURE 5 – Example of calibration set-up

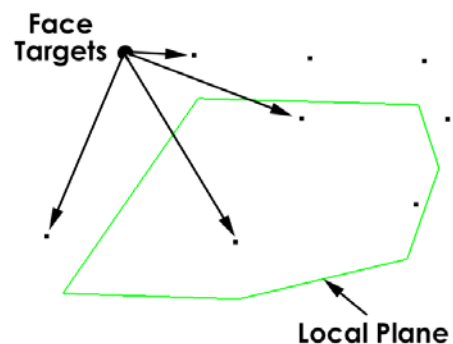

FIGURE 6 – Calibration file

At run time, a local transformation is completed for each of the FTs found. This transformation uses the calibrated and measured values of the face targets to transfer the plane, line or feature desired into the global coordinate system of the measured object.

There are four basic types of FTs. These are shown in TABLE 1.

Type	Example	Function
Plane	 <p>90° Orientation 45° Orientation</p>	The contact plane is defined.
Edge	 <p>Determined Edge Contact Planes</p>	Two contact planes and the edge derived by their intersection are defined.
Corner	 <p>Determined edge Determined corner</p> <p>Contact Planes</p>	Three contact planes, two edges and the corresponding corner are defined.
Circle	 <p>Tangent Points Center Point</p>	The center point of a circle with known radius is defined.

TABLE 1 – Basic types of FTs.

FT PROPERTIES:

The targets have a number of attractive properties. These are summarized in TABLE 2.

<i>Fast</i>	Measurement with FTs is much faster than with other methods. The setup time for sequential photogrammetry is very low compared to other in-place measurement systems. Using FTs to measure features is faster and easier in many applications than probing the feature. Photography is usually very quick. Finally, analysis is completely automated, so it is both fast and error-free.
<i>Higher Accuracy</i>	The accuracy obtained is higher than normal probed data because the FT is measured from multiple locations, and many points are used to define the feature.
<i>Line of Sight</i>	FTs can be configured and used to eliminate many line-of-sight problems.
<i>Versatile</i>	The method is extremely versatile in both its use and application. FTs can be configured to meet many measuring requirements.
<i>Minimal Downtime</i>	The fast overall measurement and analysis time means critical production downtime is minimized.
<i>Enhanced Targeting</i>	FTs can measure features that cannot be directly targeted.
<i>Repeat Measurement</i>	The ability to automate measurements through construction macros (Ganci and Handley, 1998) makes FTs ideal for repeat production measurements.

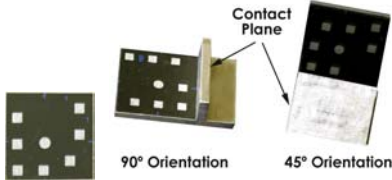
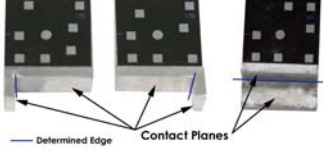
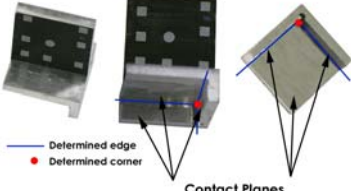
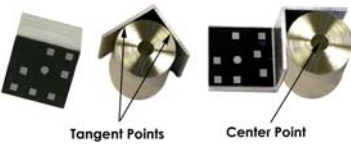
TABLE 2 – FT properties.

MEASUREMENT PROCEDURE

Use of the FTs for measurement of NC blocks on automotive fixtures is very simple. A target is placed on each block or surface that needs to be measured. The target selection will depend on the required data and the viewing angles to the block. For blocks with faces that are not perpendicular it is customary to use a combination of FTs. For pin or circle measurements it is necessary to specify the correct radius at the calibration phase. This figure typically comes from the design data. Some sample FT solutions are shown in TABLE 3.





Feature	Sample FT Solutions	
Plane	 <p data-bbox="524 825 646 848">Example 1</p>	 <p data-bbox="1052 825 1174 848">Example 2</p>
Edge	 <p data-bbox="524 1098 646 1121">Example 1</p>	 <p data-bbox="1052 1098 1174 1121">Example 2</p>
Corner	 <p data-bbox="524 1381 646 1404">Example 1</p>	 <p data-bbox="1052 1371 1174 1394">Example 2</p>
Complex corner		
Centerline		

TABLE 3 – Sample FT solutions.

CASE STUDIES – Overview

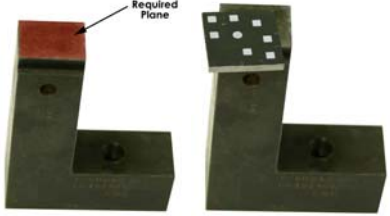
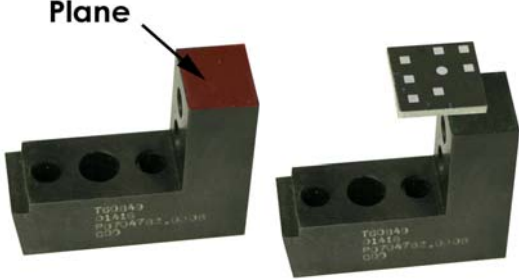
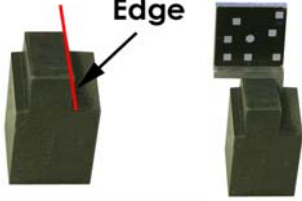
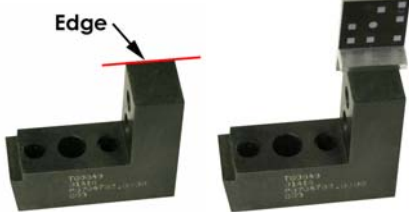
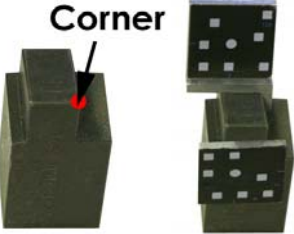
To test FTs in some actual applications, two case studies were undertaken. The studies are described in TABLE 4.

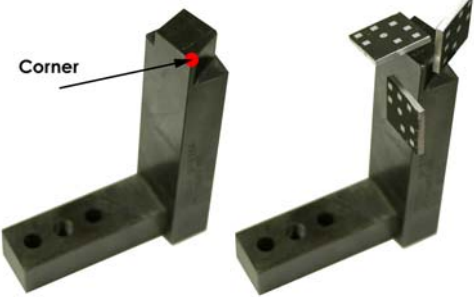

Case Study	Object	Objectives
<p>Case 1 Fixture measurement.</p>	 <p style="text-align: center;">Fixture</p>	<ol style="list-style-type: none"> 1. Use FTs to inspect the fixture. 2. To complete the inspection in less time than the current inspection system.
<p>Case 2 In-line car body inspection</p>	 <p style="text-align: center;">BMW Z3 Axle Carrier</p>	<ol style="list-style-type: none"> 1. Use FTs to inspect the underbody of a vehicle during assembly (in-line). 2. To complete the measurement in less than the production cycle time of five minutes.

TABLE 4 – Case Studies Overview.

For these two case studies, the FT concept was an attractive alternative to other measurement methods. In case study 1, analysis of production tooling requires a fast and efficient measurement system. The driving factors are time and availability for analysis. Case study 2 presents the need for immediate information for decision making during production. In both cases the need for uninterrupted production schedules is paramount.

In the case of production tooling measurement, unavailability of tooling during after-shift hours due to routine maintenance needs, and constantly changing production schedules due to high product demand, have forced inspection personnel into working during scheduled break times. This means finding a way to measure a tool during a normal 40-minute lunch break, with the goal of eventually completing the measurement during a 10-minute coffee break.

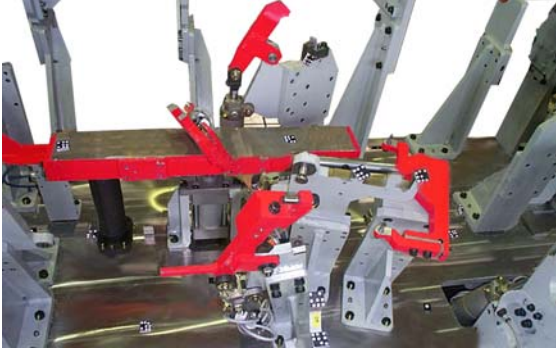
The ability to flexibly analyze product deviation in-line is the focus of the second case study. Increasingly, inspection is needed at the point of origin in order to efficiently determine a potential problem and set corrective action. The problem facing dimensional inspection is flexibility and time. The system needs to be set-up quickly and measure in unstable environments such as constantly moving assembly lines. It also needs to complete the measurement between assembly processes.

CASE 1 – Fixture Measurement

The first case study involved the measurement of a relatively simple object, namely a 1.8-meter long panel-holding fixture. The primary objective of the measurement was to determine the location of key features such as corners, edges and planes on the fixture.

FTs were placed on each of the desired features. Wherever possible, one FT was used. For features without a suitable target the necessary data was created using a combination of FTs. A sample clamping mechanism is shown in FIGURE 7. Four FTs are shown. The FT at the back of the clamp is used to define a contact plane. The three remaining FTs are used to define the hard corner of the clamping surface. The fixture measurement required a total of 40 FTs to measure all the desired features.

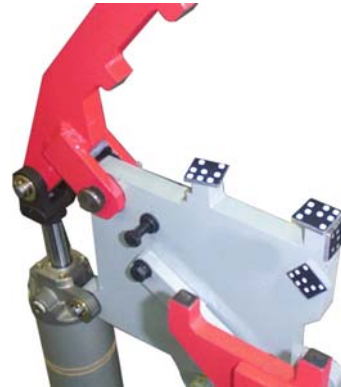

FIGURE 7 – Sample clamp

After targeting, a total of 60 photographs were taken of the fixture. The number of photos taken depends on the complexity of the measurement and accuracy requirements. The photography for the fixture was completed in approximately five minutes. Camera-station locations for the measurement are shown in FIGURE 8.

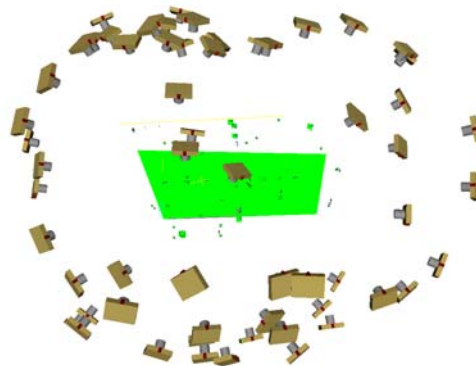

FIGURE 8 – Camera-station network

The following is a summary of the statistics from the measurement of the fixture:

No. of photos	60
No. of FTs	40
No. of scales	2
Scale Agreement	0.01mm
Accuracy RMS (mm) X,Y,Z	X 0.010
	Y 0.009
	Z 0.008

Some of the features measured on the fixture are shown in FIGURE 9. Also shown is the corresponding FT analysis.

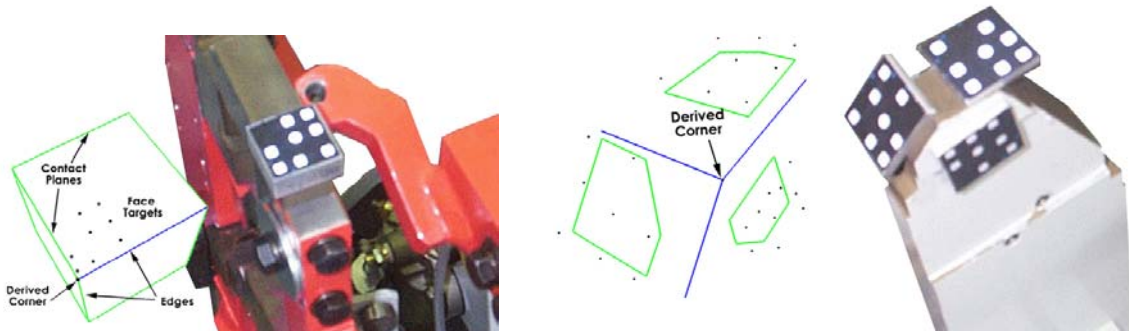

FIGURE 9 – Examples of features measured

To obtain a better idea of the time saving of FTs, the same measurement was completed using conventional stick-on targeting and the multi-camera probe system. The probes were needed to collect data on the features that could not be targeted.

A comparison of the two measurements is shown in TABLE 5.

Measurement type	FT Solution	Stick-on and probes
Number of targets	40 FTs	320
Targeting	5 minutes	25 minutes
Probing	-	15 minutes
Target removal	3 minutes	20 minutes
Photography	2 minutes	2 minutes
Processing	2 minutes	3 minutes
Analysis	3 minutes	30 minutes
TOTAL TIME	15 minutes	95 minutes

TABLE 5 - Comparison of the two measurements.

It is clear from TABLE 5 that the FT concept is far faster. The automated analysis of the FTs especially saves time while also eliminating measurement errors.

CASE 2 – Production Measurement

In the second case study FTs were used to measure the front-axle carrier of a BMW Z3. The measurement was a pilot study to examine whether in-line measurements could be used to identify cars with bushing angle problems. Rectifying these problems early in the production process would ultimately result in significant scrap-value savings further down the production line. The test unit is shown in FIGURE 10.

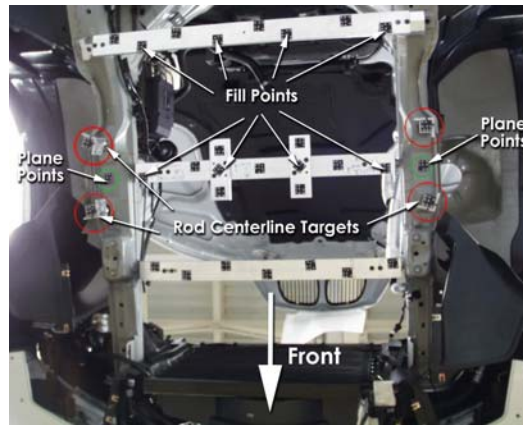

FIGURE 10 – Axle carrier

The measurement was complicated by the need to complete it within the time the car would be idle at a station. A total of five minutes was set aside for targeting, photography, and teardown. Processing the images to yield the required data was not necessary during the five-minute time limit.

Two operators performed the measurement. The targeting and teardown was completed in approximately two minutes. A total of 18 photographs were collected in less than two minutes. The network used is shown in FIGURE 11. The following is a summary of the statistics from the measurement.

No. of photos	18
No. of FTs	8
No. of scales	8
Scale Agreement	0.01mm
Accuracy RMS (mm) X,Y,Z	X 0.008
	Y 0.007
	Z 0.017

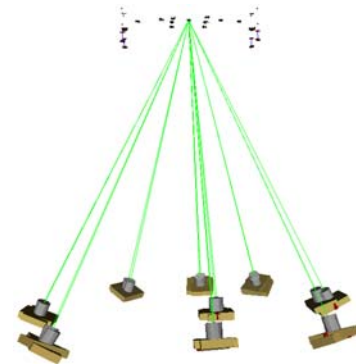

FIGURE 11 – Camera station network

Once the processing is finished, the desired features are automatically generated. In this case study, six planes, eight circles and four lines were created. The feature generation is shown graphically in FIGURE 12.

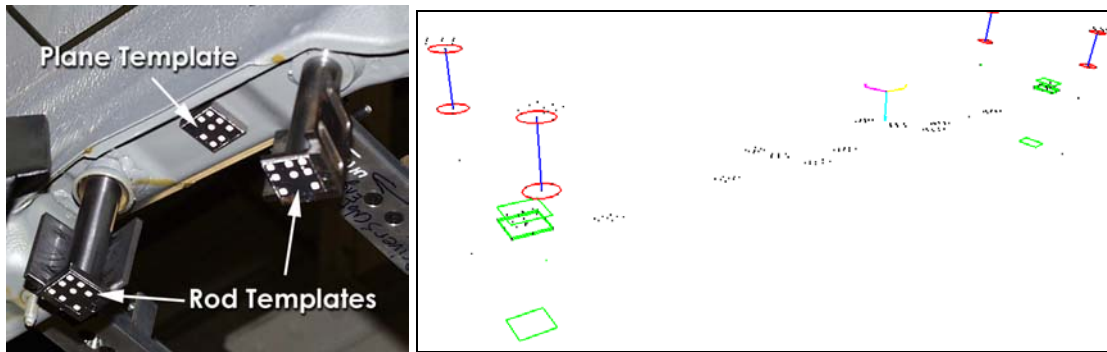

FIGURE 12 – Key measurement features and their geometric reductions

All of the objectives of the measurement were met. This study showed how FTs could be used to automate the process and significantly reduce the amount of time needed to complete such a measurement.

CONCLUDING REMARKS

This paper and the case studies described herein show that measurement using the Feature Target concept has the following useful characteristics.

- Fast overall measurement – so production downtime is minimized, and in-line measurements within one car cycle are possible.
- Automated analysis - eliminates the tedious, error prone analysis of features.
- Simple system setup and operation – the camera is small, portable and simple to set up, photography is quick and easy, and FTs eliminate the tedium and difficulties of probing features.
- Works in unstable environments – where other instruments cannot be used.

Consequently, Feature Targets are a powerful new tool for automating and simplifying the measurement of geometric features; in particular the measurement of NC blocks in automotive fixtures.

ACKNOWLEDGEMENTS

The authors wish to acknowledge the assistance of the BMW Manufacturing Corporation in providing suitable case studies for this paper. We would also like to thank John Brown and Dr George Blaha for their editorial comment.

REFERENCES

- Brown, J., 1998. V-STARS/S Acceptance Results. *Boeing Large Scale Optical Metrology Seminar*, Seattle.
- Fraser, C. S., 1997a. Automation in Digital Close Range Photogrammetry. *First Trans Tasman Surveyors Conference*, 12-18
- Fraser, C.S. 1997b. Innovations in Automation for Vision Metrology Systems. *Photogrammetric Record*, 15(90): 901-911.
- Ganci, G. and Brown, J., 2000. Developments in Non-Contact Measurement Using Videogrammetry. *Boeing Large Scale Optical Metrology Seminar*, Long Beach.
- Ganci, G. and Handley, H.B., 1998. Automation in Videogrammetry. *International Archives of Photogrammetry and Remote Sensing*, Hakodate, 32(5): 53-58